



Features

- Supports the requirements of ITU-T G.8262 for synchronous Ethernet Equipment slave Clocks (EEC option 1 and 2)
- Supports the requirements of Telcordia GR-1244 Stratum 3 and GR-253, ITU-T G.813, and G.781 SETS
- Supports ITU-T G.823, G.824 and G.8261 for 2048 kbit/s and 1544 kbit/s interfaces
- Meets the SONET/SDH jitter generation requirements up to OC-48/STM-16
- Synchronizes to telecom reference clocks (2 kHz, N*8 kHz up to 77.76 MHz, 155.52 MHz) or to Ethernet reference clocks (25 MHz, 50 MHz, 62.5 MHz, 125 MHz)
- Supports composite clock inputs (64 kHz, 64 kHz + 8 kHz, 64kHz + 8 kHz + 400 Hz)
- Generates standard SONET/SDH clock rates (e.g., 19.44 MHz, 38.88 MHz, 77.76 MHz, 155.52 MHz, 622.08 MHz) or Ethernet clock rates (e.g., 25 MHz, 50 MHz, 125 MHz, 156.25 MHz, 312.5 MHz) for synchronizing Gigabit Ethernet PHYs
- Programmable output synthesizers (P0, P1) generate telecom clock frequencies from any multiple of 8 kHz up to 100 MHz
- Generates several styles of telecom frame pulses with selectable pulse width, polarity and frequency
- Provides two DPLLs which are independently configurable through a serial interface

Ordering Information

ZL30143GGG	100 Pin CABGA	Trays
ZL30143GGG2	100 Pin CABGA*	Trays

*Pb Free Tin/Silver/Copper

-40°C to +85°C

- Internal state machine automatically controls mode of operation (free-run, locked, holdover)
- Flexible input reference monitoring automatically disqualifies references based on frequency and phase irregularities
- Provides automatic reference switching and holdover during loss of reference input
- Supports master/slave configuration and dynamic input to output delay compensation for AdvancedTCATM
- Configurable input to output delay and output to output phase alignment

Applications

- ITU-T G.8262 System Timing Cards which support 1 GbE and 10 GbE interfaces
- Telcordia GR-253 Carrier Grade SONET/SDH Stratum 3 System Timing Cards
- System Timing Cards which supports ITU-T G.781 SETS (SDH Equipment Timing Source)

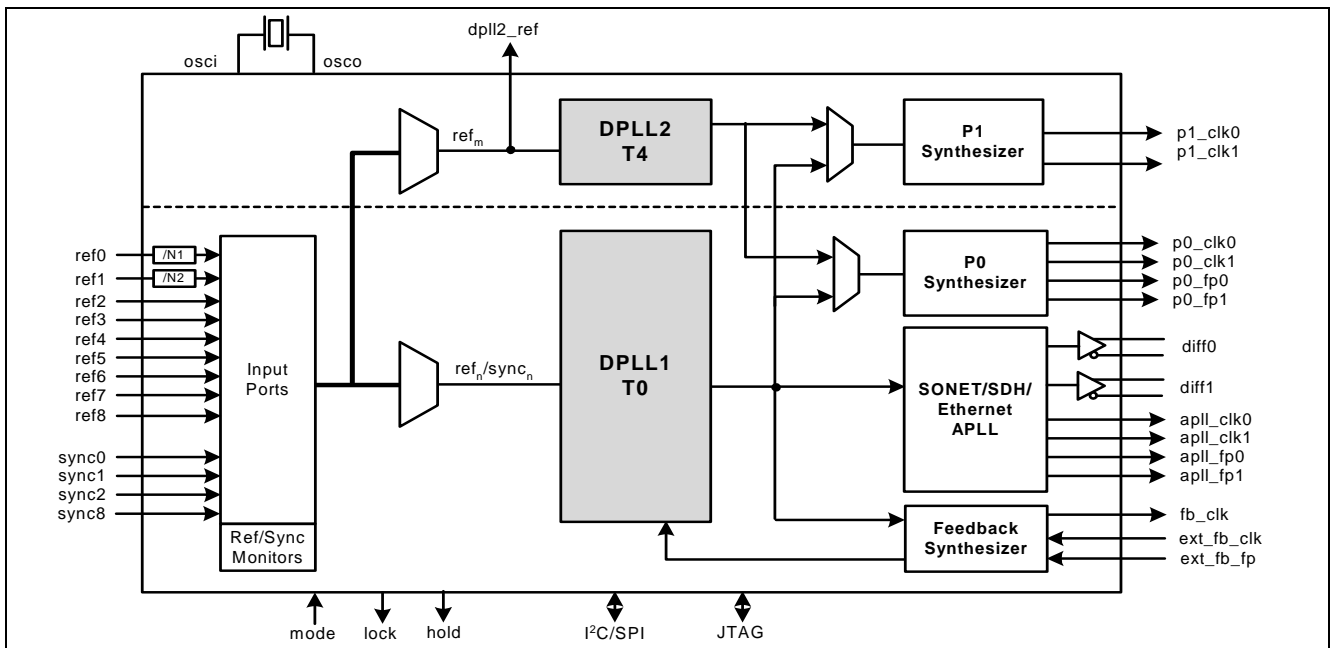

Figure 1 - Functional Block Diagram

1.0 Overview

The ZL30143 System Synchronizer and SETS device is a highly integrated device that provides all of the functionality that is required for a central timing card in carrier grade network equipment. The basic functions of a central timing card include:

- Input reference monitoring for both frequency accuracy and phase irregularities
- Automatic input reference selection
- Support of both external timing and line timing modes
- Hitless reference switching
- Wander and jitter filtering
- Master/slave crossover for minimizing phase alignment between redundant timing cards
- Independent derived output timing path for support of the SETS functionality

In a typical application, the main timing path uses DPLL1 to synchronize to either an external BITS source or to a recovered line timed source. DPLL1 monitors all references and automatically selects the best available reference based on configurable priority and revertive properties. DPLL1 provides the wander filtering function and the P0 synthesizer generates a jitter filtered clock and frame pulse for the system timing bus which supplies all line cards with a common timing reference. The APLL is used to generate a reference clock for an Ethernet PHY which can be used to synchronize remote equipment. A derived output timing path using DPLL2 is available to support the SETS function. In this case DPLL2 uses a filter above 10 Hz to prevent it from filtering wander.

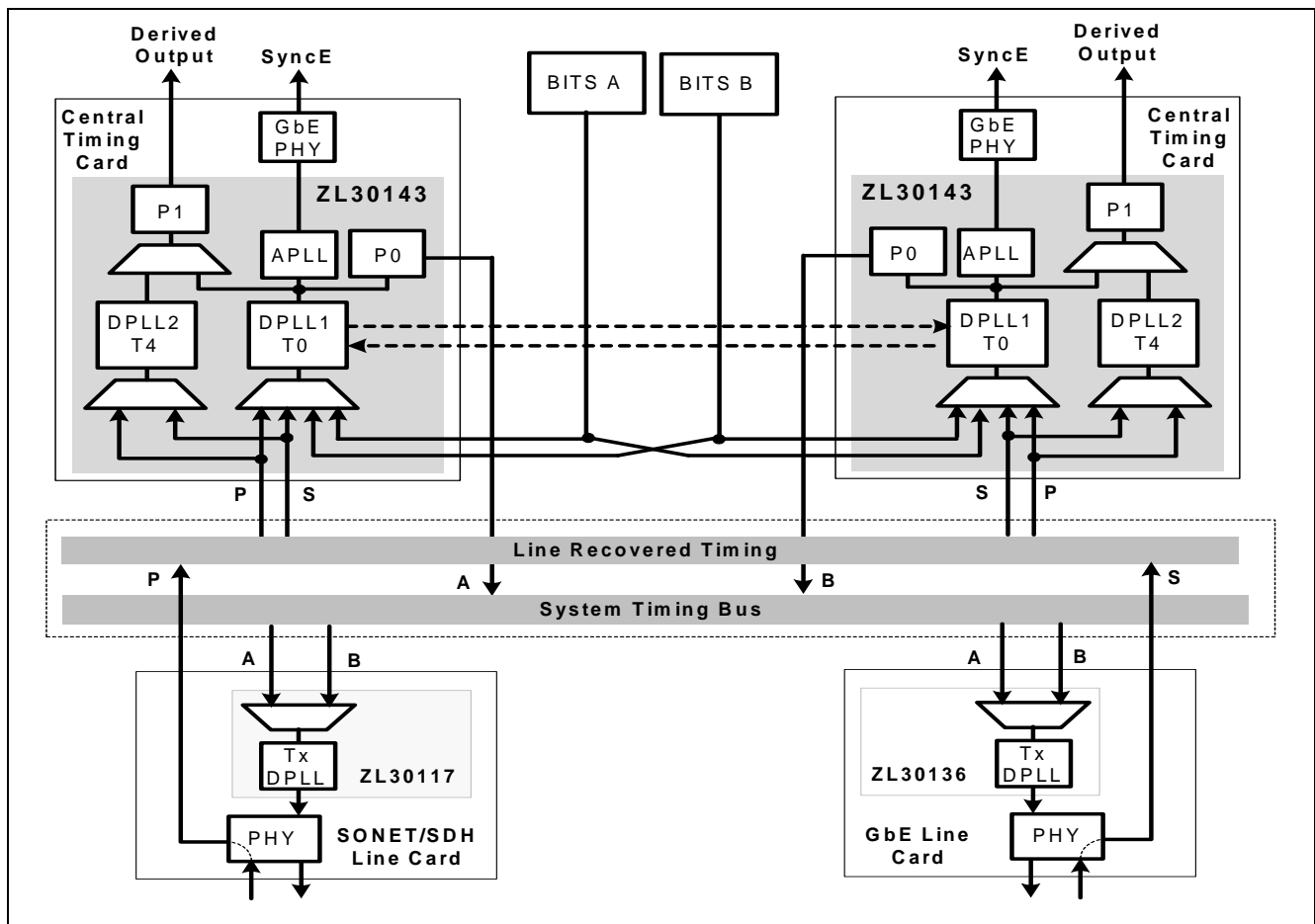
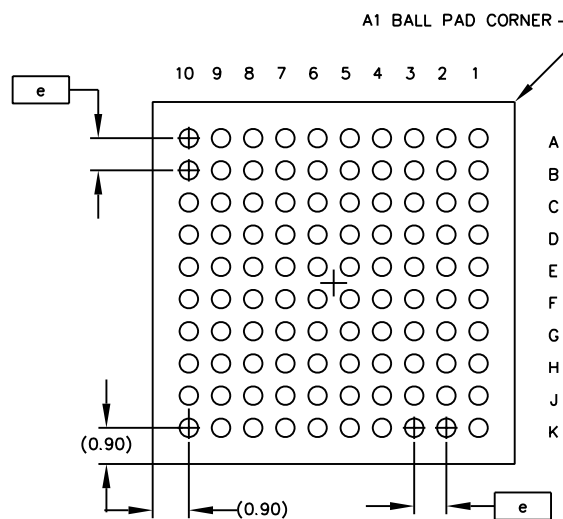
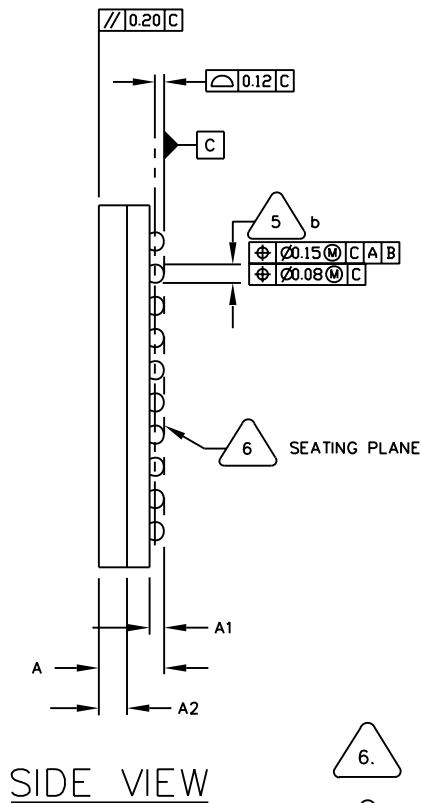
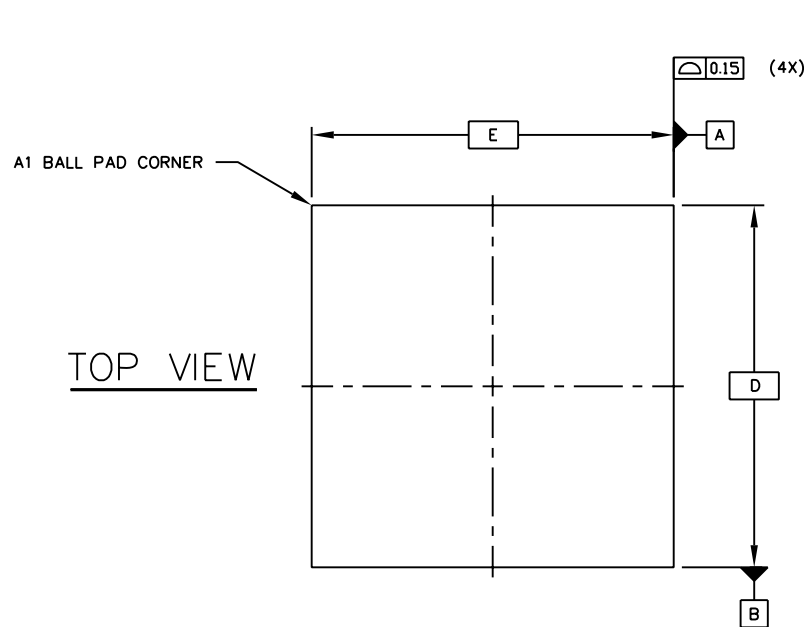

Figure 2 - Typical Application of the ZL30143



SYMBOL	MILLIMETER		
	MIN	NOM	MAX
A	1.52	1.62	1.72
A1	0.31	0.36	0.41
A2	0.65	0.70	0.75
b	0.46 Typ.		
D	8.85	9.00	9.15
E	8.85	9.00	9.15
e	0.8 Ref		
n	100		



PRIMARY DATUM C AND SEATING PLANE ARE DEFINED BY THE SPHERICAL CROWNS OF THE SOLDER BALLS.



DIMENSION b IS MEASURED AT THE MAXIMUM SOLDER BALL DIAMETER, PARALLEL TO PRIMARY DATUM C.

4.

THE MAXIMUM ALLOWABLE NUMBER OF SOLDER BALLS IS 100.

3.

Not to Scale.

2.

THE BASIC SOLDER BALL GRID PITCH IS 0.8mm.

1.

ALL DIMENSIONS AND TOLERANCES CONFORM TO ASME Y14.5M-1994.

NOTES: UNLESS OTHERWISE SPECIFIED

© Zarlink Semiconductor 2006 All rights reserved.

ISSUE	1	2	3
ACN	CDCA	CDCA	CDCA
DATE	15April05	24Aug05	26Oct06
APPRD.			



Previous package codes

N/A

Package Code GG

Package Outline for
100ball 9x9mm, 0.8 mm
Pitch, 4 layer, CABGA

111040



**For more information about all Zarlink products
visit our Web Site at
www.zarlink.com**

Information relating to products and services furnished herein by Zarlink Semiconductor Inc. or its subsidiaries (collectively "Zarlink") is believed to be reliable. However, Zarlink assumes no liability for errors that may appear in this publication, or for liability otherwise arising from the application or use of any such information, product or service or for any infringement of patents or other intellectual property rights owned by third parties which may result from such application or use. Neither the supply of such information or purchase of product or service conveys any license, either express or implied, under patents or other intellectual property rights owned by Zarlink or licensed from third parties by Zarlink, whatsoever. Purchasers of products are also hereby notified that the use of product in certain ways or in combination with Zarlink, or non-Zarlink furnished goods or services may infringe patents or other intellectual property rights owned by Zarlink.

This publication is issued to provide information only and (unless agreed by Zarlink in writing) may not be used, applied or reproduced for any purpose nor form part of any order or contract nor to be regarded as a representation relating to the products or services concerned. The products, their specifications, services and other information appearing in this publication are subject to change by Zarlink without notice. No warranty or guarantee express or implied is made regarding the capability, performance or suitability of any product or service. Information concerning possible methods of use is provided as a guide only and does not constitute any guarantee that such methods of use will be satisfactory in a specific piece of equipment. It is the user's responsibility to fully determine the performance and suitability of any equipment using such information and to ensure that any publication or data used is up to date and has not been superseded. Manufacturing does not necessarily include testing of all functions or parameters. These products are not suitable for use in any medical products whose failure to perform may result in significant injury or death to the user. All products and materials are sold and services provided subject to Zarlink's conditions of sale which are available on request.

Purchase of Zarlink's I2C components conveys a license under the Philips I2C Patent rights to use these components in an I2C System, provided that the system conforms to the I2C Standard Specification as defined by Philips.

Zarlink, ZL, the Zarlink Semiconductor logo and the Legerity logo and combinations thereof, VoiceEdge, VoicePort, SLAC, ISLIC, ISLAC and VoicePath are trademarks of Zarlink Semiconductor Inc.

TECHNICAL DOCUMENTATION - NOT FOR RESALE
