

## PRODUCT PREVIEW

**WORLD'S FIRST INTEGRATED SOLUTION FOR VOICE APPLICATIONS THAT IMPLEMENTS COMPLETE BORSCHT FUNCTIONALITY IN A SINGLE DEVICE. THE VE880 SOLUTION IS THE EASIEST AND MOST COST EFFECTIVE WAY TO ADD VOICE TO BROADBAND CONNECTIONS.**

The VE880 VoicePort™ Series is the world's first two-channel FXS telephone line interface solution to implement complete BORSCHT functionality in a single device.

The VE880 VoicePort Series devices significantly increase design flexibility, improve system performance and reduce system BOM cost. Simply stated, VoicePort products give a designer the easiest and most cost effective way to add voice to voice enabled consumer premise equipment.



VE8820 Chipset

880 VoicePort Series	
2FXS	
150V Tracking	VE8820 Chipset
	Le88276
100V ABS	Le88266
120V ABS	Le88286

### Features

- ➔ Complete BORSCHT functionality in a single device—highest level of integration reduces system BOM and discrete component count
- ➔ Smallest footprint—saves board space
- ➔ 110-V, 120-V or 150-V ringing, integrated balanced or unbalanced ringing, narrow band or wide band—Offers flexibility to develop one application for worldwide markets
- ➔ Design options for power management—provides options for low power tracking or cost effective ABS power supplies
- ➔ Integrated switching regulator—enables lowest component count and highest efficiency in all states of operation
- ➔ Worldwide programmable—flexibility to develop one application for worldwide transmission and signaling
- ➔ Integrated ring cadencing and system state control—reduces real-time software overhead
- ➔ Comprehensive line sensing and line monitoring with VeriVoice Test Suite software—provides complete GR-909 diagnostics, subscriber loop test, self test, and supervision functions

### Applications

- ➔ Voice Enabled Cable and xDSL modems
- ➔ Residential VoIP Gateways and Routers
- ➔ Fiber To The Premise/Home (FTTP/H) CPE, e.g. Optical Network Terminal (ONT)
- ➔ Wireless Local Loop (WLL), ISDN
- ➔ Enterprise PBX/KTS
- ➔ Set-Top Box

## APPLICATION

Zarlink provides a world-class suite of development tools to facilitate the integration of Legerity voice solutions into end-user applications and to significantly reduce design time.

The VoicePath API-II™ (VP API-II) is a set of 'C' code used to abstract devices from application code while providing functions for controlling, supervising, packet exchanging, and testing a set of subscriber lines. It is application and OS independent in that it requires no memory (only memory required is provided by application space) and supports reentrancy. It has been used in Linux (application and kernel space), VxWorks, and non-OS architec-

tures. The API-II is common across all Legerity voice solutions so applications written for one device are the same for other devices. It integrates seamlessly with the Zarlink's Legerity Software Development Kit (SDK) Tools so your development time is significantly reduced.

The VeriVoice™ Test Suite is a subscriber line software package for VoIP equipment, providing the market's most cost effective and reliable solution for VoIP line test while at the same time minimizing the cost of ownership for service providers. Self-test available with VeriVoice Professional.

### Le882xx VoicePort Devices

Options for 150V tracking & 100V/120V ABS FXS Channels

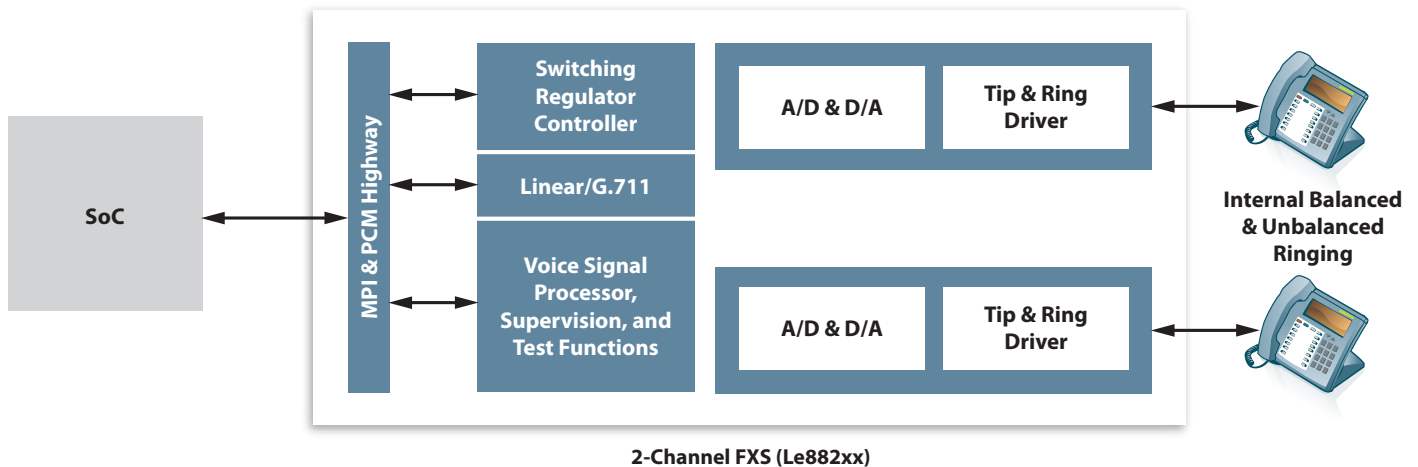

Information relating to products and services furnished herein by Zarlink Semiconductor Inc. or its subsidiaries is believed to be reliable. The products, their specifications, services and other information appearing in this publication are subject to change by Zarlink without notice.

ZARLINK, ZL, and the Zarlink logo are trademarks of Zarlink Semiconductor Inc.

© 2010, Zarlink Semiconductor Inc. All Rights Reserved. Publication Number 10ZS161



[www.ZARLINK.com](http://www.ZARLINK.com)